



广州恒宽机械有限公司

Canton Hostandard Machinery CO., LTD

www.pocket-spring.com

Email: hostandard@hotmail.com

Mob: 0086-133-1411-7277

Skype: northland99

袋装弹簧生产机 Pocket spring coiler HS-PSM70

Photo Details

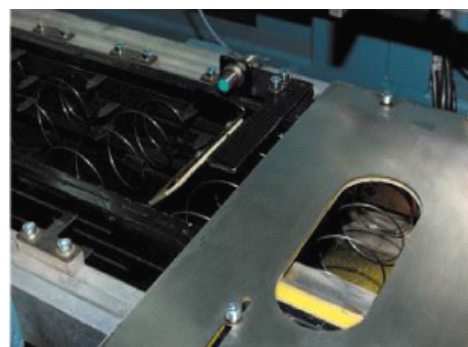
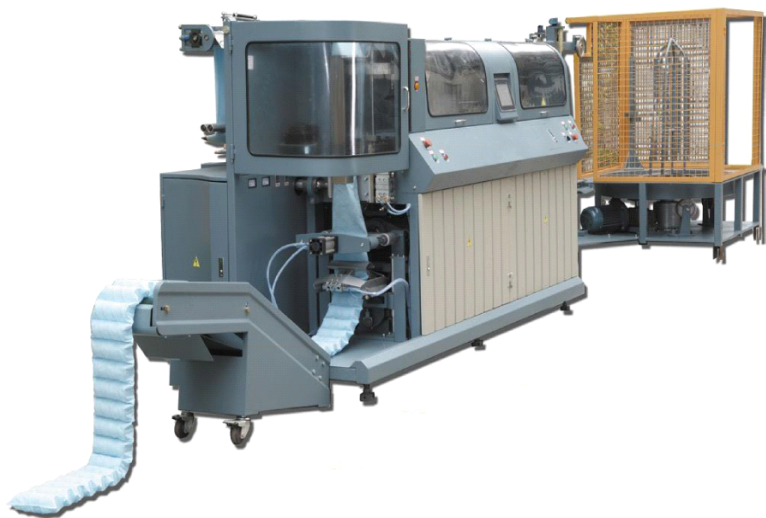

video weblink:<http://u.youku.com/northland99>

Technical Information:

Performance 生产效率

| | | |
|---------------------|------------|----------------|
| production capacity | 生产速度(只/分钟) | 70 springs/min |
|---------------------|------------|----------------|

Consumptive Material Specs 耗材参数

| | | | |
|-------------------------|---------------------------------|-------|-----------------------|
| steel wire 钢丝 | wire gauge | 钢丝直径 | 1.6--2.2mm |
| | Iner Dia. of wire roll | 钢丝卷内径 | Min/最小320mm |
| | Outer Dia. of wire roll | 钢丝卷外径 | Max/最大1000mm |
| | Max weight of wire roll | 钢丝卷重量 | Max/最大800kg |
| Non-woven fabric 无纺布 | Fabric density | 布料厚度 | 65~90g/m ² |
| | Fabric width | 布料宽度 | 450-600mm |
| | Inner dia.of fabric roll | 布辊内径 | Min/最小60mm |
| | Outside diameter of fabric roll | 布辊外径 | Max/最大600mm |

| General Data 一般参数 | | | | |
|----------------------------|---------------|------------|-----------------------------|----------------------|
| Spring type | | 弹簧形状 | Barrel(直筒型) Cylindrical(鼓形) | |
| Air consumption | | 气源需求量 | Approx/约30m ³ /h | |
| Air pressure | | 工作气压 | 0.6-0.7mpa | |
| Power consumption in total | | 总功率 | Approx/约12KW | |
| Power requirements | Voltage | 电压 | 3AC 380V | |
| | Frequency | 频率 | 50/60Hz | |
| | Input fuse | 保险丝 | 25A | |
| | Cable section | 输入电缆 | 4×10mm ² | |
| Working temperature | | 工作温度 | +5℃—+45℃ | |
| Weight | | 重量 | Approx/约2450kg | |
| Output Range 产品规格 | | | | |
| | | Wire Gauge | Spring Waist Diameter | Pocket spring height |
| | | 钢丝直径 (d) | 弹簧中腰直径 (D) | 弹簧入袋后高度 (H) |
| Standard/常规 | A | φ1.6-φ2.1 | φ55-φ70 | 80-140 |
| | B | φ1.6-φ2.1 | φ55-φ70 | 120-180 |
| | C | φ1.6-φ2.1 | φ60-φ75 | 80-140 |
| | D | φ1.6-φ2.1 | φ60-φ75 | 120-180 |
| | E | φ1.6-φ2.1 | φ60-φ75 | 140-200 |
| Special/特殊 | S1 | φ1.3-φ1.6 | φ45-φ55 | 70-120 |
| | S2 | φ1.3-φ1.6 | φ45-φ55 | 120-180 |
| | S3 | φ1.0-φ1.4 | φ37-φ45 | 60-120 |
| | S4 | φ1.0-φ1.4 | φ37-φ45 | 120-180 |
| | S5 | φ1.6-φ2.1 | φ50-φ60 | 180-230 |
| | S6 | φ1.6-φ2.1 | φ60-φ70 | 180-230 |
| | S7 | φ1.6-φ2.1 | φ50-φ60 | 240-300 |
| | S8 | φ1.6-φ2.1 | φ60-φ70 | 240-300 |

Footprint 占用空间

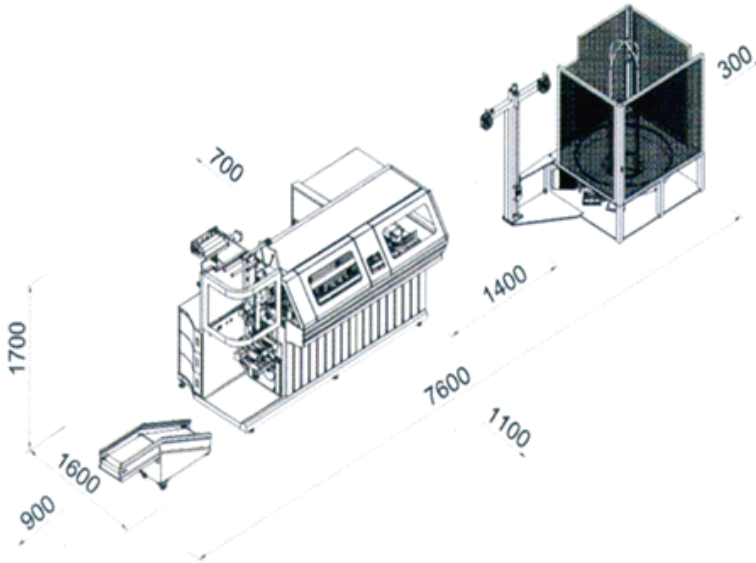

AFTER-SALE SERVICE 售后服务

PACKAGING INFO 包装信息

| | | | |
|----------------------|---|----------------------------|-----------------|
| installation: | new machine installation free | packing material: | wood or plywood |
| | expenditures of way and accommodation paid by customer. | package count: | |
| | | Packing dimensions: | |
| warranty: | 1 year | Volume: | |
| | free spare parts offered during warranty | gross weight: | |
| spare parts: | spare parts list offered. | net weight: | |

ADDITIONAL COMMENTS&REMARK

*Payment terms: T/T 30% deposit in advance, balance 70% 3 days before shipment.

*Agent policy: in some countries or areas, you can ask our agent for efficient service.